

## Installation Data Sheet

### GA Shuffle-Less Glazing System (intended for interior applications only)

1

Please read these instructions before using this product. If there is anything you do not understand or if you want to know more about this item, please contact GA.

GA Glazing Channels must be installed by suitably qualified contractors with the required knowledge and expertise. Current standard construction methods must be used.

The contractor, has the responsibility and duty to ensure proper safety during and after completion of the installation, so that the GA Shuffle-less Glazing System remains safely secured to the attached surfaces.

Before beginning the installation, please refer to our Health & Safety Data Sheet, for guidance regarding off-loading, Site Storage etc.

#### GA Shuffle-less Glazing System consists of the following parts:

Aluminium alloy sections:



Head channel (SA1031/PCW1031) c/w pre-drilled holes for 4mm dia. csk. screws.

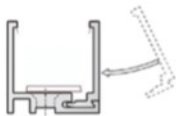

Floor channel (SA1035/PCW1035) c/w pre-drilled holes for 4mm dia. csk. screws.

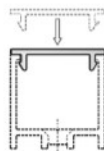

Cover plate (SA1036/PCW1036) *optional*

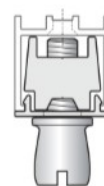

Door pivot kit (SA1040/PCW1040) *optional*

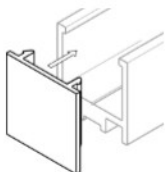

End Caps (SA1037/PCW1037) *optional*

The additional items listed below are supplied along with all the head & floor channels:

- PVC glazing wedge (gasket)
- Plastic setting blocks

GA Helpline 020 8692 2255 Mon-Fri 8.30am-5pm for professional assistance

[www.goodngalum.com](http://www.goodngalum.com) [sales@goodngalum.com](mailto:sales@goodngalum.com)

© Gooding Aluminium Limited



## Installation Data Sheet

### GA Shuffle-Less Glazing System (intended for interior applications only)

2

#### Fixing

**Step 1.** Carefully unpack the profiles and ensure they are in good condition & fit for purpose.

**Step 2.** Select suitable quality fixings that are appropriate for use with the intended fixing surface.

**Step 3.** If required, cut away any unwanted jig marks from the profile ends, before fixing commences.

**Step 4.** Locate the head channel (SA1031/PCW1031) into the required position and secure by inserting fixings through the pre-drilled countersunk holes into a sound and secure surface.

**Step 5.** To ensure vertical alignment use a plumb bob or laser to the outside of the vertical flanges of the head and base/floor profiles (SA1035/PCW1035) (not to the screw fixing holes, as these are not centred on the base/floor profile) by inserting fixings through the countersunk holes into a sound and suitable surface.

**Step 6.** Once the main part of the base/floor channel has been secured, and before inserting the glass panel, place the plastic setting blocks (included) at approximately 400mm centres along the horizontal internal surface of the profile.

**Step 7.** Using the appropriate vacuum lifters or equivalent, carefully lift the glass panels up and into the inside of the head channel before lowering down onto the plastic setting blocks that are resting upon the horizontal surface inside the base/floor channel.

**Step 8.** With the glass in position, locate the 2nd part of the base/floor glazing profile so that it interlocks with the 1st part, then proceed to Step 9a or 9b.

**Step 9a.** For 10mm thick glass fit the glazing wedge (gasket) continuously along both sides of the head channel (SA1031/PCW1031) & the base/floor channel (SA1035/PCW1035). Ensure the wedge (gasket) is safely secured onto the horizontal nib of each vertical leg.

or

**Step 9b.** For 12mm thick glass firstly peel away the removable tag that runs continuously along the side of each wedge/gasket. Then follow the fitting instructions given in the above (9a) paragraph.

**Step 10.** If required, the optional aluminium cover plate (SA1036/PCW1036) and end caps (SA1037/PCW1037) can be snapped into place.

**Step 11.** Once the installation is complete, the protective film covering the aluminium surfaces can be peeled away.

For further guidance, an installation video can be viewed on the GA website Shuffle-Less Glazing System product page.

Important Note: -

Profile SA1035/PCW1035 is only intended for use as a base/floor channel and is not to be installed otherwise.

See next page >

GA Helpline 020 8692 2255 Mon-Fri 8.30am-5pm for professional assistance

[www.goodngalum.com](http://www.goodngalum.com) [sales@goodingalum.com](mailto:sales@goodingalum.com)

© Gooding Aluminium Limited

## Installation Data Sheet

### GA Shuffle-Less Glazing System (intended for interior applications only)

#### GA Door Suspension Kit

##### Comprises: -

Aluminium alloy extruded block with pre-drilled & threaded csk. hole, as well as 3 fixing holes.

- Pivot Pin
- Pre-drilled cover plate

##### Fixing

**Step 1.** With the glass panels fixed into position, push the pivot block up into the head channel (SA1031/PCW1031).

**Step 2.** Slide the pivot block into position and secure with fixings through the pre-drilled fixing holes into a suitable fixing surface.

**Step 3.** Trim the pre-drilled cover plate at both ends to suit your pivot point, and snap into the head channel (ensuring that the 10mm dia. pre-drilled hole is aligned with the pre-drilled and threaded hole in the pivot block).

**Step 4.** Pass the pivot pin through the pre-drilled cover plate and screw fix into the threaded hole in the pivot block.

N.B. The pivot block is 114mm in length (half the pivot point of 57mm), therefore it can be pushed/positioned into position either way around against a fixed glass panel (this dimension suits patch fittings) to create a 3mm gap between the door and side panel.

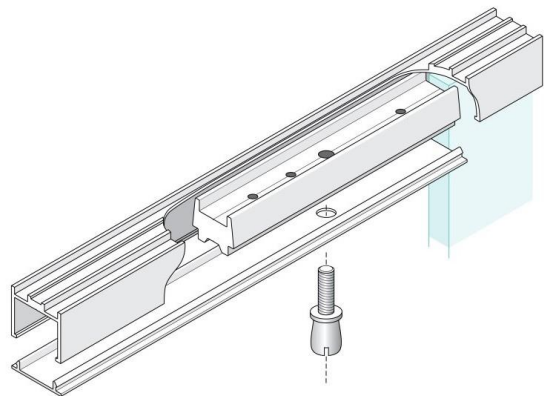

#### Cleaning and Maintenance

All that is normally required to maintain the appearance and prevent the build-up of surface contaminants on the visible surfaces is an occasional wipe over with a soft, dry cloth.

Any liquids being used for cleaning purposes must be applied in small amounts to a soft cloth.

Grease or oil deposits can be removed with organic solvent such as white spirit, followed by wiping over with a mild diluted detergent and rinsing with cold clean water. Dry off with a soft cloth.

It is important that abrasive cleaners or scourers are not used on aluminium as they may damage the surface.

Regular checks should ensure that the glazing wedge (gasket) is firmly secured between the aluminium channels and the glass panels.

GA Helpline 020 8692 2255 Mon-Fri 8.30am-5pm for professional assistance

[www.goodngalum.com](http://www.goodngalum.com) [sales@goodingalum.com](mailto:sales@goodingalum.com)

© Gooding Aluminium Limited